

# RUBBER CONVERSION TOOLS & TECHNIQUES

A COMPREHENSIVE GUIDE FOR ALL OF YOUR RUBBER CONVERSION NEEDS

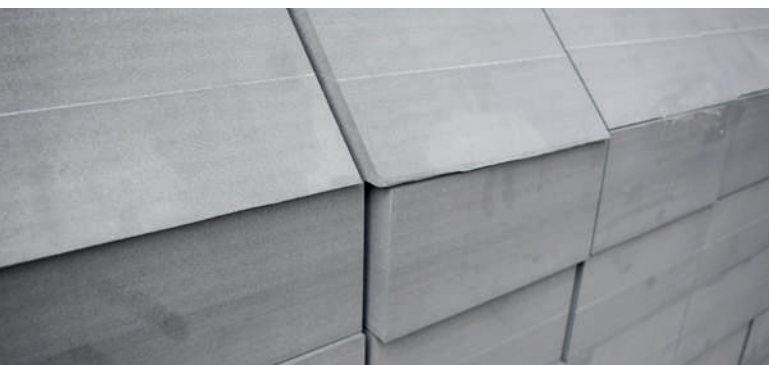

ISO  
9001 : 2015  
REGISTERED

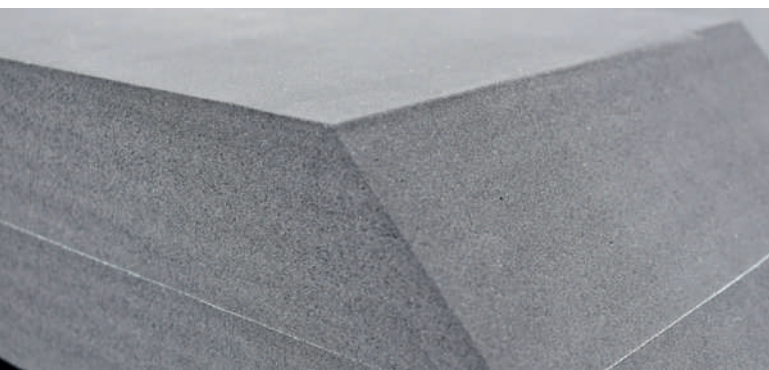

## Rubber Conversion Specialists

Rubber compounds are typically available in a wide range of formats, shapes and sizes. Here at The Rubber Company we specialise in converting rubber into usable end products in order to suit our customer's needs. Utilising a variety of tools and techniques we are able to convert sponge rubber into high quality, bespoke products. We understand that no two requirements will ever be the same, so we tailor each project to suit your specific requirements. We can work with you every step of the way from providing useful technical and material advice during the design process through to manufacturing material samples prior to bulk production.



Manufacturers · Designers · Distributors

Experts in  
**Rubber**

# POPULAR CONVERSION TECHNIQUES

We have listed a selection below of our most commonly used conversion tools and techniques. These techniques can be utilised on a variety of material compounds in order to achieve a range of formats. It is worth noting however, that our conversion capabilities are always expanding and our processes are not limited to this list.

## Slitting

Slitting machines are ideal for horizontally cutting sheets of sponge rubber from large blocks of raw material. The roller ensures that consistent pressure is applied in order to achieve tight tolerances regardless of the material used. Slitting is widely considered the most popular method for converting blocks of rubber in sheeting for use end use or for further converting.

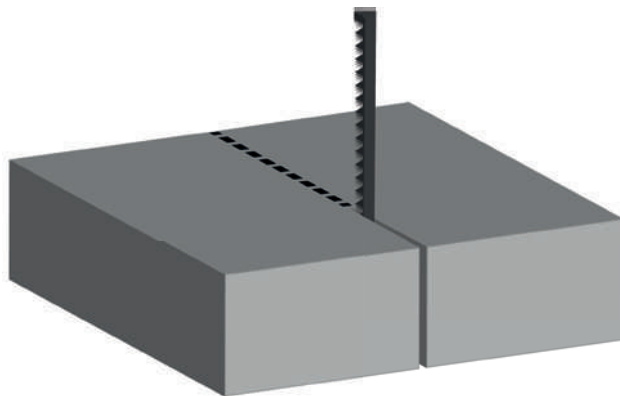
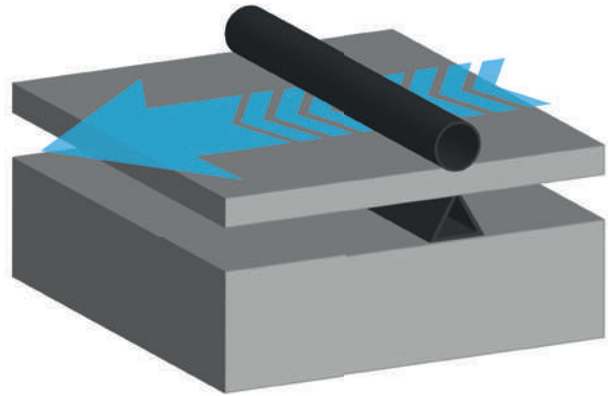

## Bandsaw & Band Knife

Bandsaws are utilised to vertically cut basic shapes and designs from rubber sheets or blocks. The main advantage of bandsaws is the tools relatively quick set up and process time. This can help to reduce lead times on larger orders. Bandsaws can also achieve consistently clean cuts.

## Oscillating Blade

Oscillating blades, also known as CNC cutting machines are essentially computer-controlled bandsaws with a much smaller blade. Much like bandsaws CNC machines cut vertically, however the set-up is different. The main benefit in using oscillating blades is that the blade is controlled by a computer which enables it to cut intricate shapes quickly and repeatedly.

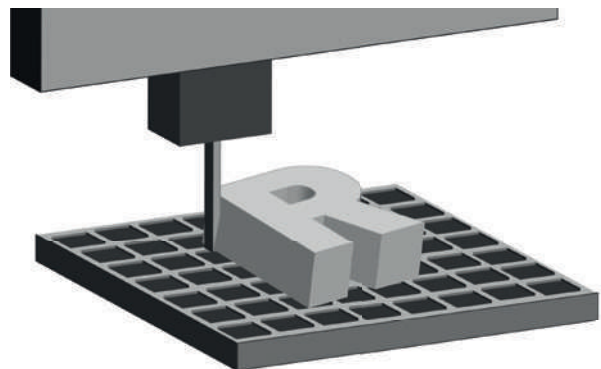

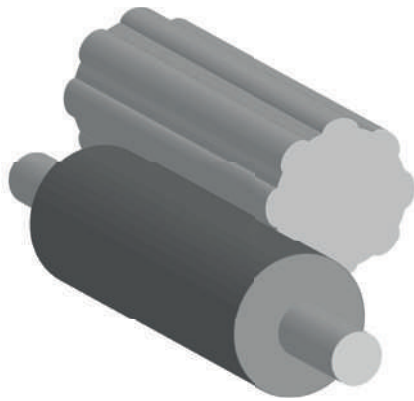

## Grinder

Grinder machines are typically used to grind down sponge and foam rubber from a sheet or block into a cylindrical shape. As the grinder is able to apply consistent pressure we can achieve highly accurate measurements, which are maintained across the length of the shape.

## Boring

Boring tools are used to create inner diameters or "cut-outs" in sponge rubber. The tool is incredibly easy to set up and use, which makes it easy to create multiple cuts. The blade section can be swapped out in order to cut a variety of diameters.

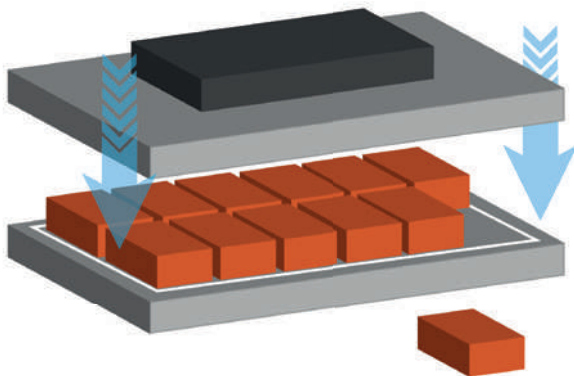
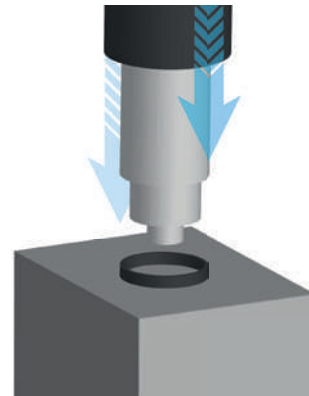

## Die Stamping

Die stamping machines utilise a hydraulic press in order to accurately cut out 3D shapes. Once set up the machine can consistently cut shapes to the same size. Die stamping is typically used for medium to large production runs as it is able to cut multiple shapes at a time.

## Mangle / Nip Roller

Nip rollers are typically used to provide pressure in order to improve the adhesion of self-adhesive backing to sponge and foam sheets. The rollers enable us to feed the material through to ensure that the pressure is applied to the whole sheet. This results in an adhesive backing that is able to withstand regular movement and impact.

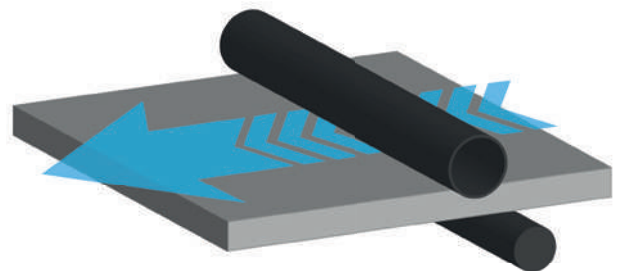

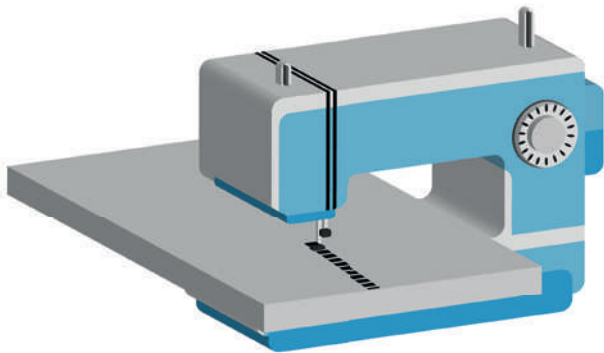

## Sewing

We regularly utilise sewing machines to produce out stitched bellows. Sewing machines are ideal for joining two or more materials together, as long as the application doesn't require a waterproof barrier. Using sewing machines, we can easily create any length, width or shape required. This technique is also useful for creating material samples prior to bulk production.

## Laser Cutting

Laser cutting machines are ideal for cutting highly intricate shapes and designs. We can also use laser machines to add bespoke details and designs to materials. As laser cutting machines are computer controlled it is possible to consistently replicate detailed designs.

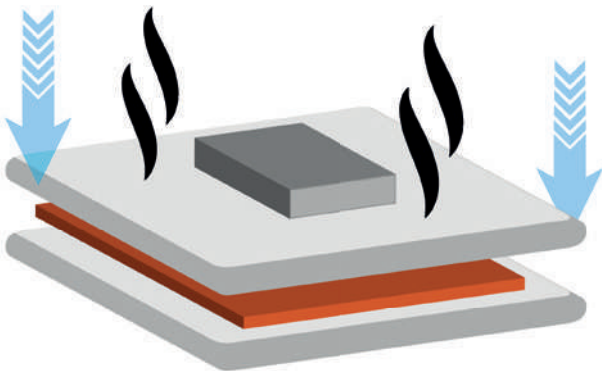
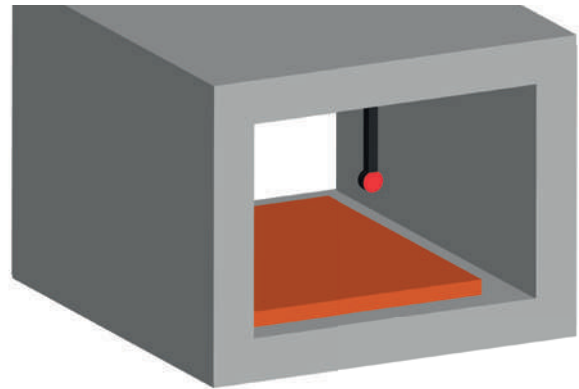

## Cooking

Cooking machines are used to achieve high temperatures in order to improve the strength of joins between multiple cut pieces. The machine is very easy to set up with cooking times varying depending on the material and number of pieces used.

## Gluing

Utilising gluing and welding enables us to adapt our standard profiles and sheet sizes to fit our customers specific application. This is typically used to join two profiles together in order to fit in a corner or around a particular radius. The set up and process is very quick, which makes this method ideal for small to medium production runs.

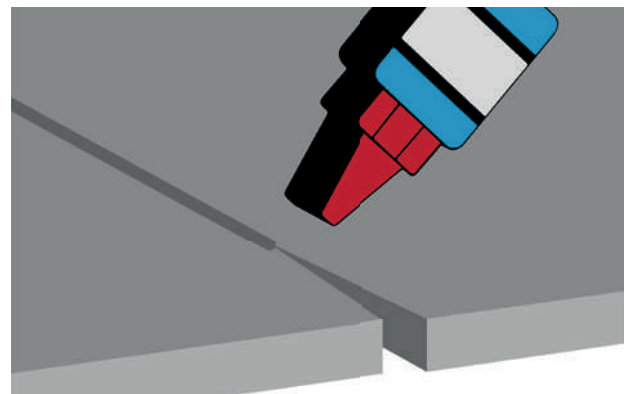

# MATERIAL SAMPLE & SELECTION CARD

Aside from utilising a wide range of conversion tools and techniques, The Rubber Company can also provide an extensive selection of materials and grades. Many of these materials are suitable for use in a variety of applications and industries, however certain materials tend to lend themselves towards more specialist applications. In order to help make the material selection process as quick and easy as possible we offer material sample card. Our material sample card contains 24 of our most popular and versatile materials. Each material is given a brief description as well as important technical information such as: densities, temperature ranges and standard sizes. Our sample card also contains a small cut-out of each material to give you a tactile feel for the material and density.

MATERIAL SAMPLE CARD

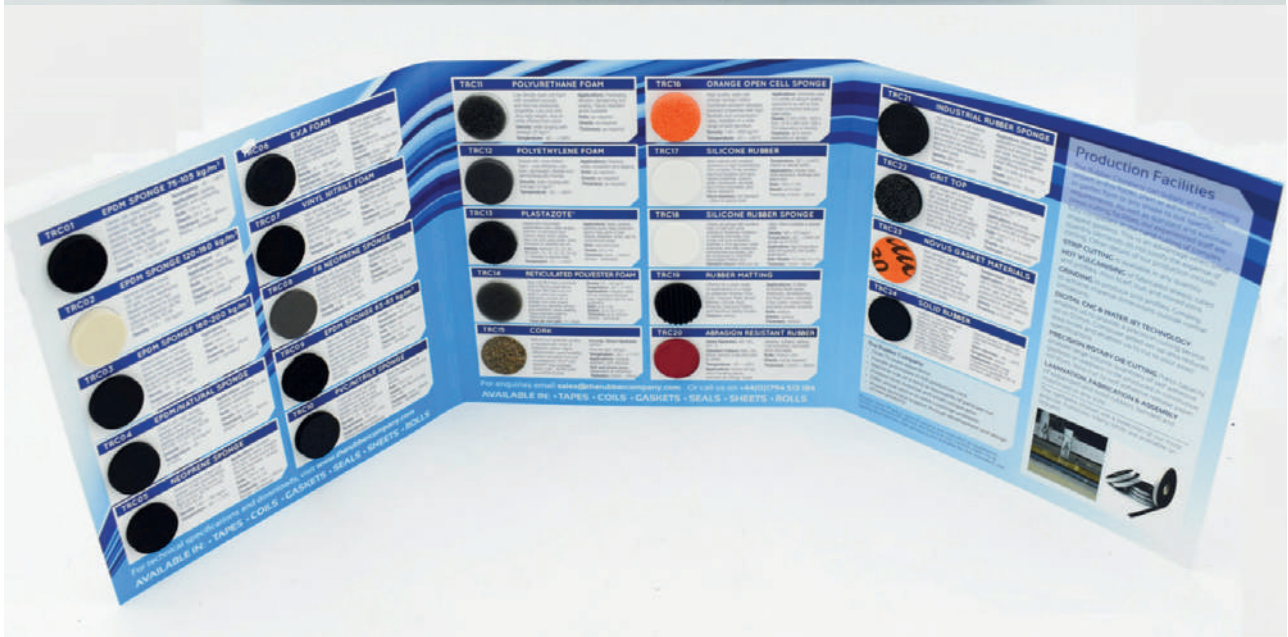

# POPULAR CONVERSION MATERIALS

## TRC01

### EPDM SPONGE 75 - 105 kg/m<sup>3</sup>

This is a closed cell material, that combines good flexibility, tensile strength and recovery properties in a single package. It also features good resistance against UV light deterioration and has a working temperature range from -30°C to +80°C. We can supply this material in a variety of densities from 75 to 105 kg/m<sup>3</sup>.



## TRC02

### EPDM SPONGE 120 - 160 kg/m<sup>3</sup>

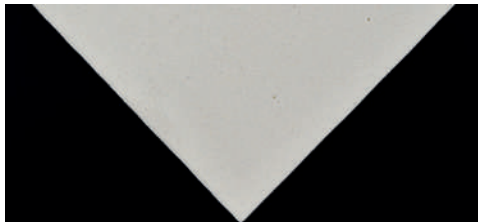

This is a white, general purpose, closed cell EPDM sponge material. It provides good resistance against UV light, Ozone as well as weathering deterioration. It features a working temperature range from -30°C to +80°C. We can supply this particular material in densities ranging from 120 to 160 kg/m<sup>3</sup> as standard.

## TRC03

### EPDM SPONGE 180 - 200 kg/m<sup>3</sup>

This is a high density, closed-cell, general purpose material. It features good resistance to UV light, Ozone and weathering deterioration. It is a popular material for use in gasket and cushioning applications. It has a working temperature range from -30°C to +100°C. We supply this material in densities ranging from 180 to 200 kg/m<sup>3</sup>.



## TRC04

### EPDM & NATURAL RUBBER SPONGE



This material is manufactured from a combination of EPDM and natural rubber sponge. This enhances the material's physical properties, which makes it suitable for use in robust sealing applications. It has a working temperature range from -30°C to +100°C. We supply this material in densities ranging from 270 to 330 kg/m<sup>3</sup>.

## TRC05

### NEOPRENE SPONGE 140 - 190 kg/m<sup>3</sup>

This is a general purpose, closed-cell material. It features good flexibility and provides resistance against UV light, Ozone and oil deterioration. It has a working temperature range from -40°C to +75°C. We can supply this particular material in densities ranging from 140 to 190 kg/m<sup>3</sup> in thicknesses from 1mm to 40mm as standard.



## TRC06



This material is a cross-linked, vinyl acetate foam. It provides superior durability when compared to polyethylene foam. It is also available in a wide selection of colours. It has a working temperature range from -60°C to +80°C. We supply this material in densities ranging from 25 to 160 kg/m<sup>3</sup>.

## EVA FOAM

## TRC07

This is a high density, closed-cell foam that combines high impact absorption with flexibility. This material is commonly used in personal body protection equipment such as helmets. It has a working temperature range from -30°C to +60°C. We supply this material in densities ranging from 190 to 210 kg/m<sup>3</sup>.

## VINYL NITRILE FOAM



## TRC08



## FLAME RETARDANT NEOPRENE

This material is a closed-cell flame retardant and self-extinguishing grade. It fully complies with UL94-HF1 and FMVSS302 fire safety standards. It has a working temperature range from -40°C to +80°C. We supply this material in densities ranging from 130 to 170 kg/m<sup>3</sup> in thicknesses from 1mm to 40mm as standard.

## TRC09

This is an open-cell material, which provides excellent, high performance sealing capabilities. It features good recovery without deformation and also performs well under uneven compressive force. It has a working temperature range from -20°C to +70°C. We supply this material in densities ranging from 65 to 85 kg/m<sup>3</sup>.

## EPDM SPONGE 65 - 85 kg/m<sup>3</sup>



## TRC10



## PVC & NITRILE SPONGE

This is a soft to the touch, closed-cell sponge with a smooth outer skin. It features good resistance against heat, oil and weathering deterioration and is also flame retardant. It has a working temperature range from -40°C to +116°C. We supply this material in densities ranging from 75 to 95 kg/m<sup>3</sup>.

# POPULAR CONVERSION MATERIALS

## TRC11

Polyurethane foam is a low density, open-cell material that provides excellent acoustic and thermal conductive properties. It is ultra-light weight, cost efficient and available in grey or white. It has a working temperature range from  $-40^{\circ}\text{C}$  to  $+100^{\circ}\text{C}$ . We can supply this material in an average density of  $28\text{ kg/m}^3$ .

## POLYURETHANE FOAM

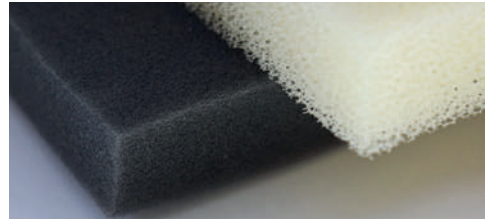

## TRC12



This is a closed-cell, cross-linked foam that is lightweight, flexible, non-toxic and dermatologically friendly. It has a working temperature range from  $-30^{\circ}\text{C}$  to  $+80^{\circ}\text{C}$ . We can supply this particular material in a wide variety of densities, with an average of  $33\text{ kg/m}^3$  in a range of sizes and thicknesses to suit your application.

## POLYETHYLENE FOAM

## TRC13

This material is a closed-cell, cross-linked polyethylene foam. It is available in a range of polymer combinations to suit your specific application and is also available in a wide variety of colours. It has a working temperature range from  $-70^{\circ}\text{C}$  to  $+105^{\circ}\text{C}$ . We supply this material in densities ranging from  $15$  to  $60\text{ kg/m}^3$ .

## PLASTAZOTE®

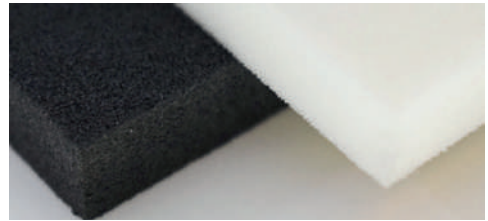

## TRC14



## RETICULATED POLYESTER FOAM

This is an open-cell filter foam, which is commonly used in filtering applications. Polyester foams do not swell in water, fuel, soaps, detergents, mineral oils or greases. It has a working temperature range from  $-40^{\circ}\text{C}$  to  $+116^{\circ}\text{C}$ . We supply this material in densities ranging from  $23$  to  $36\text{ kg/m}^3$  as standard.

## TRC16

This is a high quality, open-cell sponge rubber that combines high flexibility and compression rates with excellent abrasion resistance. It is also available in a range of pore densities to suit your application. It has a working temperature range from  $-40^{\circ}\text{C}$  to  $+80^{\circ}\text{C}$ . We supply this material in densities from  $140$  to  $600\text{ kg/m}^3$ .

## ORANGE OPEN CELL SPONGE





# Experts in Rubber

Safety Matting  
Extrusions  
Fendering  
Fabrications  
Mouldings  
Sheeting  
Sponge & Foam  
Gaskets & Seals  
Hose & Ducting  
Noise Insulation  
Custom Parts

Call us now: +44 (0) 1794 513 184



Working with companies  
worldwide



The Rubber Company Limited Registered in England and Wales  
27 Romsey Industrial Estate, Greatbridge Road, Romsey,  
Hampshire, SO51 0HR United Kingdom  
Company Number 08350831 | VAT Number GB 156 8355 80