

Self Grip Top Seal 20mm x 32mm

Product Code: RCTS20X32L

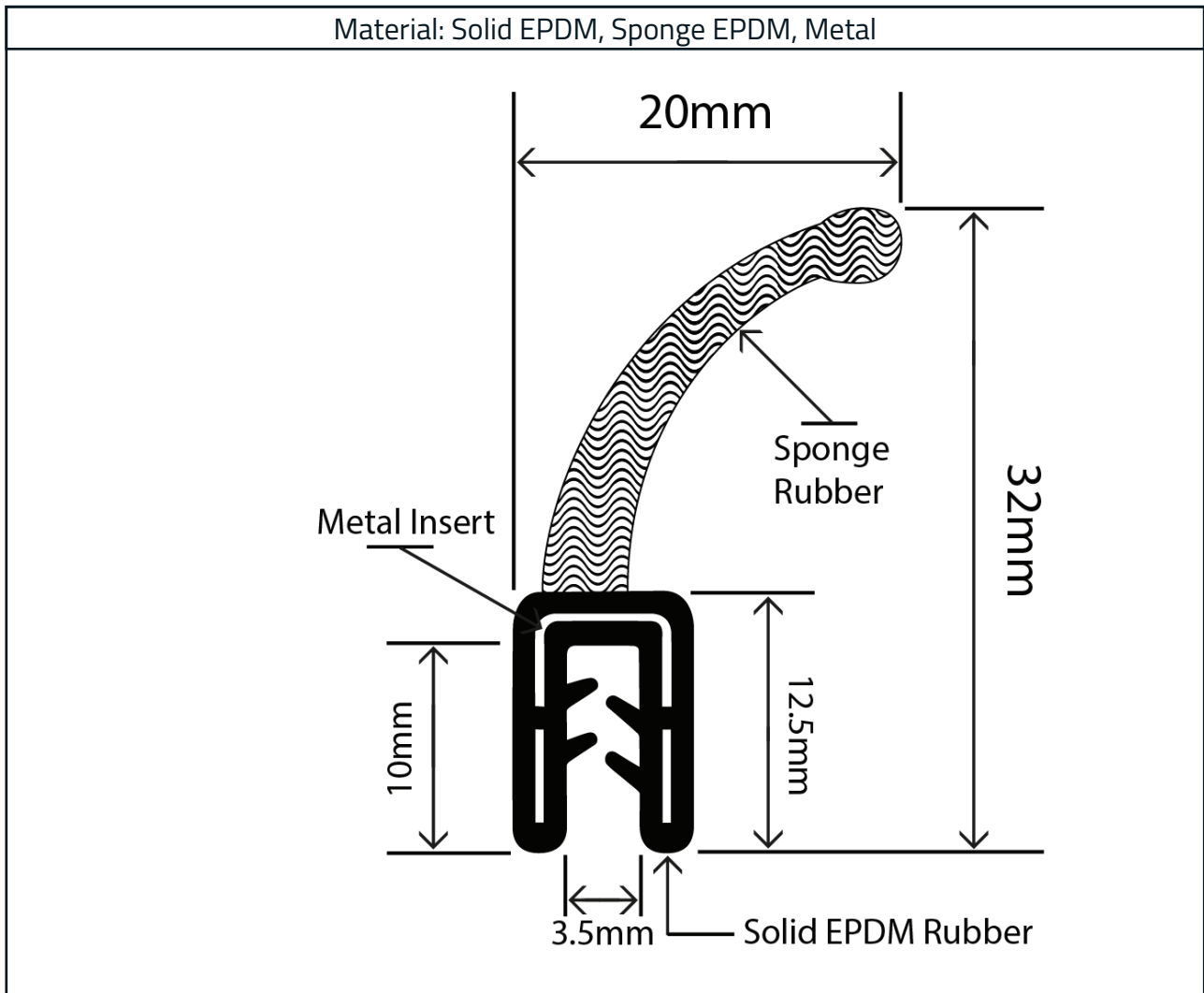

Measurements:

Height	Width	To Fit Panel
32mm	20mm	1mm - 2mm

The information contained on this product information sheet is to be used as guidance. The advice is given in good faith and does not constitute any guarantee or recommendation for suitability. The Rubber Company cannot be held liable for any damage caused by incorrect installation. We hereby reserve the right to change the technical information herewith without notification or prior agreement.



Manufacturers · Designers · Distributors

Experts in
Rubber

Material Specification - Solid Rubber Body

Our self grip top seal profiles are manufactured using a combination of solid rubber and sponge rubber with a metal carrier. These profiles provide dual functionality; they provide a sealing function while also covering sharp or unfinished edges. The hollow sponge rubber sections are extremely flexible and are suitable for sealing doors, hatches and numerous other applications.

Recommended Compression

The compression of our top seal profiles should not exceed a maximum of 50%, as otherwise the compactness and the restoring force are affected. In practice, the profile should ideally be compressed between 30-40%.

Material Specification - Solid Rubber Body

Properties	Test Method	Values
Polymer	-	EPDM
Hardness (Shore A)	ASTM D2240	80° +/- 5°
Tensile Strength	ASTM D412	80 kg/cm ² (min)
Tear Resistance	ASTM D624	3 kg/mm (min)
Brittle Point	ASTM D746	-40°C
Air Ageing (70hrs @ 70°C)		
Compression Set	ASTM D395 Type B	40% (max)
Change in Shore Hardness	-	+2°
Change in Tensile Strength	-	+15%
Ozone Resistance (70hrs @ 50°C, 50 pphm ozone concentration with 20% elongation)	ASTM D1149	No cracks

The information contained on this product information sheet is to be used as guidance. The advice is given in good faith and does not constitute any guarantee or recommendation for suitability. The Rubber Company cannot be held liable for any damage caused by incorrect installation. We hereby reserve the right to change the technical information herewith without notification or prior agreement.

E sales@therubbercompany.com • W www.therubbercompany.com • T +44 (0) 1794 513 184

The Rubber Company Limited - Registered in England and Wales
Company Number - 08350831 | VAT Number - GB 156 8355 80

Material Specification - Sponge Rubber Seal

Properties	Test Method	Values
Polymer	-	EPDM
Volume Mass (Indicative)	-	550 - 600 g/cm ³
Brittle Point	ASTM D746	-40°C
Ozone Resistance (70hrs @ 50°C, 50 pphm ozone concentration with 50% elongation)	ASTM D1149	No cracks
Water Absorption (22hrs @ 23°C)	ASTM D1056	1.2% (max)
Tensile Strength	ASTM D412	7 - 10 kg/cm ²
Tear Resistance	ASTM D624	0.6 / 0.8 kg/mm

Material Specification - Metal Carrier

Properties	Test Method	Values
H.R.B (Rockwell Hardness)	-	80 - 90
Tensile Strength	-	50 kg/mm ² (min)
Type: Fe 50 – UNI 5961 – 67		

Profile Properties

Properties	Test Method	Values
Compression Set (7 days @ 70°C)	ASTM D1056	50% (max)
Stain of the Material in Contact with Organic Finished - Migration Stain - Contact Stain	ASTM D925	Satisfactory Satisfactory
Colour Fastnesses	ASTM D750	Satisfactory
Operating Temperature Range	-	-40°C to +80°C



The information contained on this product information sheet is to be used as guidance. The advice is given in good faith and does not constitute any guarantee or recommendation for suitability. The Rubber Company cannot be held liable for any damage caused by incorrect installation. We hereby reserve the right to change the technical information herewith without notification or prior agreement.