

# EXTRUDED RUBBER CONE FENDERS

SIZE & PERFORMANCE GUIDE FOR ALL OF YOUR  
IMPACT PROTECTION NEEDS

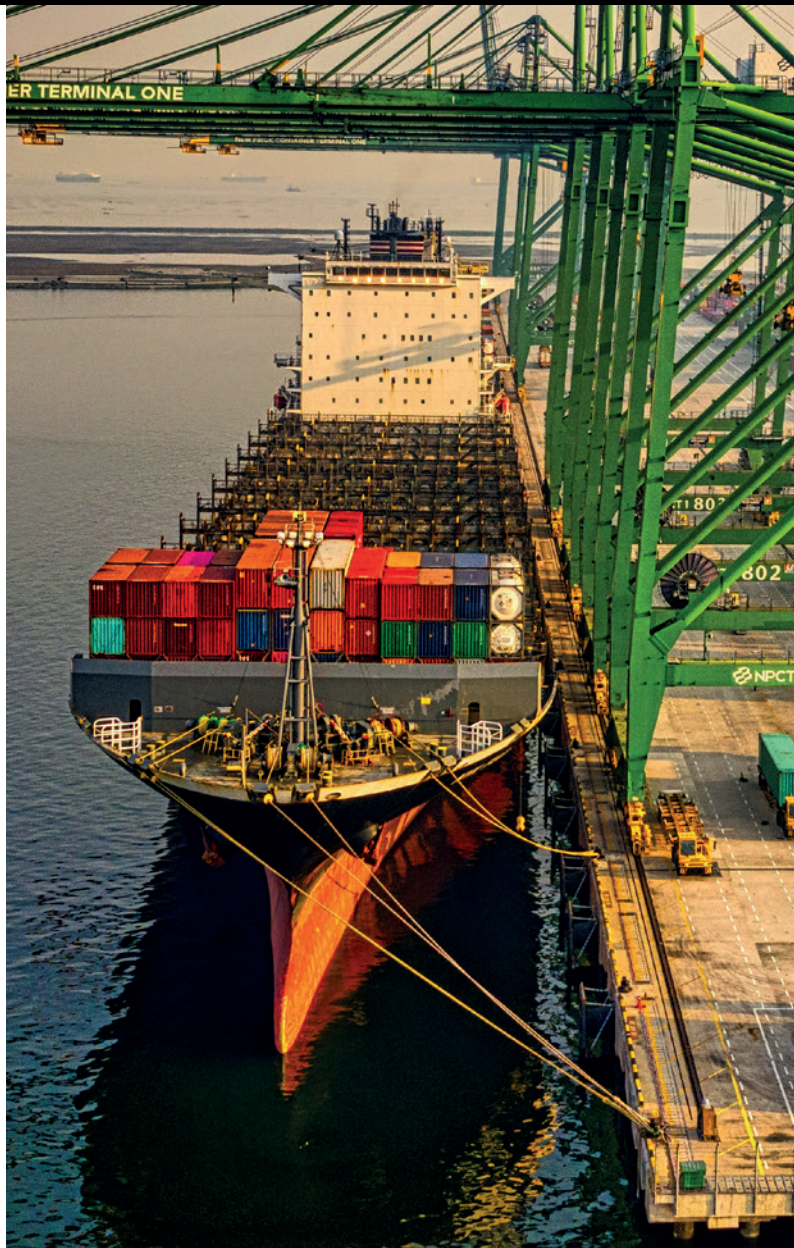

ISO  
9001 : 2015  
REGISTERED



Manufacturers · Designers · Distributors

Experts in  
**Rubber**

# CONE TYPE FENDERS INFORMATION

## Key Features

- Highly efficient even in severe angular berthing
- PIANC standard approved
- Incredibly stable cone fender shape resists shear
- Strong and maintains performance
- Versatile design suits numerous applications
- Wide choice of rubber compounds
- Proven design with thousands installed worldwide
- Wide variety of sizes available
- Supports a range of weights

## Potential Applications

- Container terminals
- Cargo berths
- Oil facilities
- RoRo & cruise terminals
- Dolphins & monopiles
- Multi-user berths
- General cargo terminals
- Naval applications



Our rubber cone fenders are manufactured from a high-quality rubber compound, and have been specifically designed for use in marine berthing applications. They combine excellent energy absorption with low reaction force upon contact in order to berth vessels of all sizes. Our cone fenders are the technological evolution of "cell" fenders, providing the most efficient performance of any fender type.

The conical design of our rubber cone fenders has been developed to provide stability at all times, regardless of the shear, axial or angular force. The large circular base also allows for secure installation to a wide variety of surfaces. It ensures that any energy is deflected away from the marina or dock. Cone fender systems can be used to berth a range of ship types such as; RoRo, Tankers and Cruise Ships. It is also suitable for use on structures such as; container and bulk terminals, general cargo facilities.

Rubber cone fenders use a design that is strong, well proven and used by facilities worldwide. For superior abrasion and wear resistance, The Rubber Company can provide steel frontal frames with a UHMW-PE face. This not only aids in the berthing process, but also serves to increase the life expectancy of the fenders. The UHMW-PE face can be swapped out, ensuring that the fender system provides optimal energy absorption at all times.

# CONE TYPE FENDER SIZE GUIDE

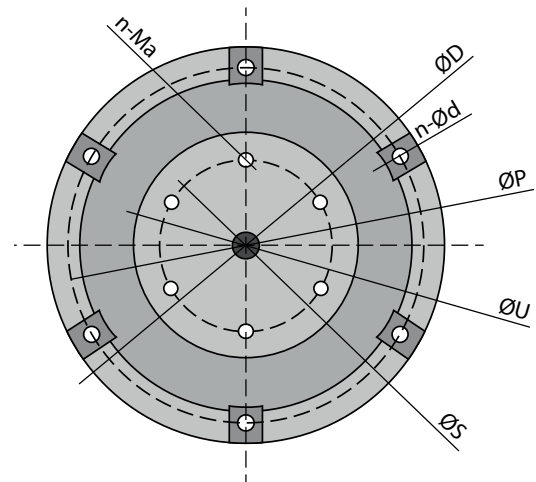
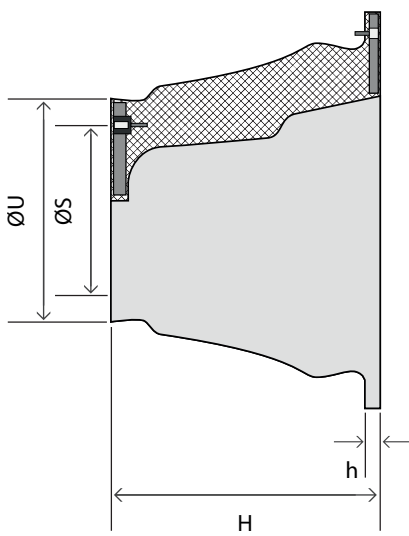

CONE TYPE FENDER SIZE GUIDE

Model	H	h	$\varnothing U$	$\varnothing S$	$\varnothing P$	$\varnothing D$	n	n- $\varnothing d$	n-Ma
TRC-500H	500	25	425	325	675	750	4	30	M24
TRC-600H	600	27	510	390	810	900	6	30	M24
TRC-700H	700	32	595	455	945	1050	6	38	M30
TRC-800H	800	36	680	520	1080	1200	6	44	M36
TRC-900H	900	41	765	585	1215	1350	6	44	M36
TRC-1000H	1000	45	850	650	1350	1500	6	56	M42
TRC-1100H	1100	50	935	715	1485	1650	6	50	M42
TRC-1150H	1150	52	998	750	1550	1725	6	56	M42
TRC-1200H	1200	54	1020	780	1620	1800	8	50	M42
TRC-1300H	1300	59	1105	845	1755	1950	8	60	M48
TRC-1400H	1400	66	1190	930	1890	2100	8	60	M48
TRC-1600H	1600	72	1360	1060	2160	2400	8	70	M48
TRC-1800H	1800	78	1530	1190	2430	2700	10	76	M56

[Units: mm]



# CONE FENDER PERFORMANCE TABLE

CONE TYPE FENDER PERFORMANCE

Model		FS - 70%	FS - 72%	FH - 70%	FH - 72%	FO - 70%	FO - 72%	FL - 70%	FL - 72%
TRC-500H	E	80.6	91.8	64.3	71.4	47.9	51	37.7	41.8
	R	342	388	273	317	204	237	168	197
TRC-600H	E	160	164	130	132	95.9	106	76.5	86.7
	R	490	553	390	438	289	325	230	263
TRC-700H	E	240	248	185	196	153	157	122	127
	R	665	705	532	579	320	435	314	348
TRC-800H	E	375	388	300	322	229	257	183	212
	R	879	949	720	850	512	588	410	437
TRC-900H	E	504	527	407	440	312	341	260	275
	R	1099	1213	879	976	648	717	518	569
TRC-1000H	E	682	750	552	600	446	488	357	388
	R	1366	1537	1100	1237	800	900	641	712
TRC-1100H	E	847	882	663	695	505	538	416	441
	R	1459	1601	1169	1248	946	1039	816	850
TRC-1150H	E	1050	1125	900	957	679	731	543	600
	R	1799	2025	1420	1625	1059	1175	847	937
TRC-1200H	E	1115	1172	971	1018	719	754	571	599
	R	1883	2086	1526	1698	1128	1252	908	1005
TRC-1300H	E	1617	1673	1336	1387	1064	1099	765	816
	R	2168	2358	1739	1938	1346	1567	1148	1224
TRC-1400H	E	1720	1791	1376	1433	1101	1147	877	914
	R	2300	2556	1840	2045	1472	1636	1173	1304
TRC-1600H	E	2467	2570	1974	2056	1579	1645	1259	1311
	R	3084	3213	2313	2570	1850	2056	1146	1606
TRC-1800H	E	3609	3760	2887	3007	2309	2406	1840	1918
	R	3825	4249	3060	3400	2449	2720	1950	2168

FS: Super High Reaction Force  
 FH: High Reaction Force  
 FO: Standard Reaction Force  
 FL: Low Reaction Force  
 E: Energy Absorption  
 R: Reaction Force

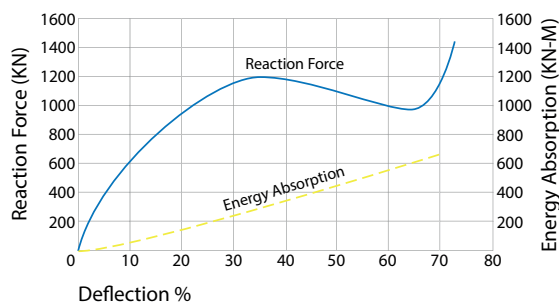

[Units: kNm, kN]

# CONE TYPE FENDER MATERIAL DATA



CONE TYPE FENDER MATERIAL DATA

Properties	Test Method	Values
Product	-	Cone Fender
Compound	-	Natural Rubber / SBR
Hardness (Shore A)	-	Varies depending on material & design
Density (Specific Gravity)	DIN 53505	1200 kg/m <sup>3</sup>
Tensile Strength	DIN 53504	≥ 16 MPa
Elongation at Break	DIN 53504	≥ 350%
Tear Resistance (23°C)	DIN 53507	≥ 80 N/cm
Abrasion Resistance	DIN 53516	≤ 100mm <sup>3</sup>
Compression Set (24hrs @ 70°C)	DIN 53517	≤ 40%
Ozone Resistance (ppm 20% 72hrs @ 40°C)	ISO 143/1	No cracking visible by eye
Minimum Operating Temperature	-	-30°C
Maximum Operating Temperature	-	+70°C

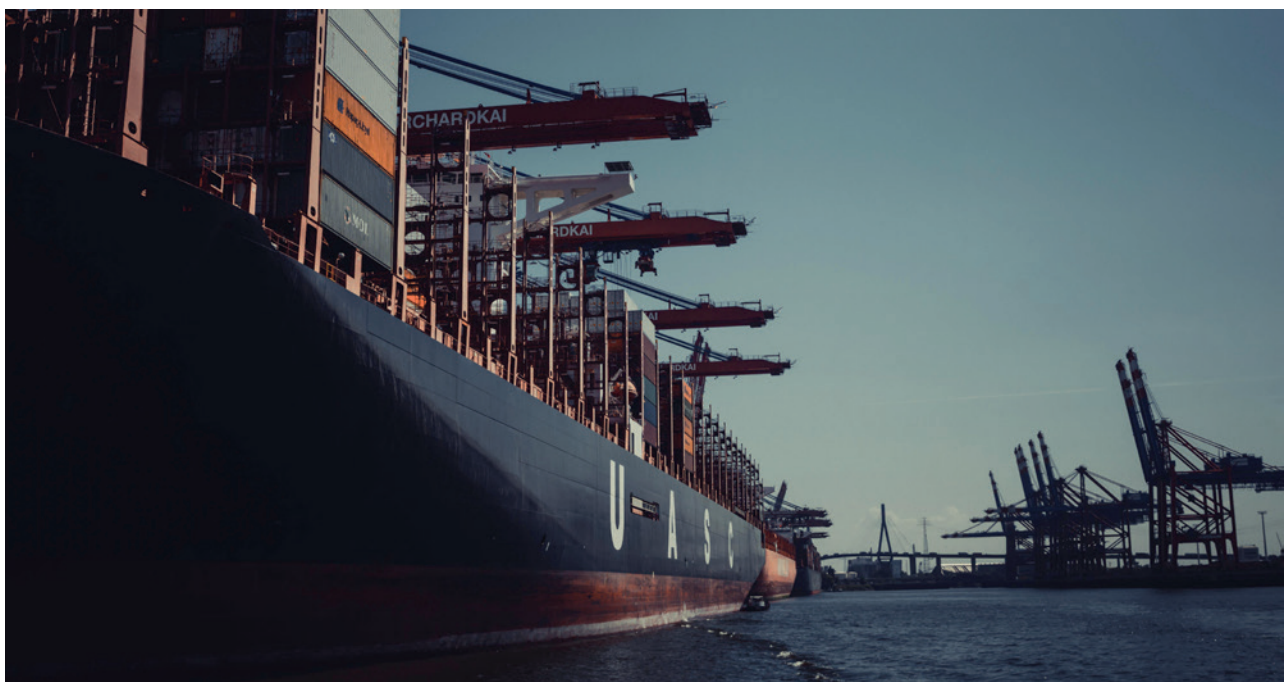

# ALTERNATIVE MARINE SAFETY PRODUCTS WE OFFER

Aside from our extruded rubber D fenders The Rubber Company can also supply a wide range of impact absorption and protection products, which have been designed specifically for marine applications. We always manufacture our products using the highest quality compounds available in order to ensure that you get a product, which is fit for purpose and made to last.

With over 75 years of experience we have a broad knowledge of the demands of the marine industries. However, we also understand that every application is different and we will work with you to ensure that you get the perfect product to match your unique requirements.

Some of our most popular marine safety products include:

- D Fenders
- Arch Fenders
- Cell Fenders
- Cylindrical Fenders
- Floating Fenders
- Fender Bars
- UHMW-PE Sliding Fenders

Don't hesitate to contact us for:

Rubber Extrusion Poster



Materials Sample Card - Gaskets, Seals, Washer, Sheet & Strip



# Experts in **Rubber**

Safety Matting  
Extrusions  
Fabrications  
Hatch Seals  
Mouldings  
Sheeting  
Sponge & Foam  
Gaskets & Seals  
Hose & Ducting  
Noise Insulation  
Custom Parts

Official Distributor

Call us now: +44 (0) 1794 513 184



Working with companies  
worldwide



The Rubber Company Limited Registered in England and Wales  
27 Romsey Industrial Estate, Greatbridge Road, Romsey,  
Hampshire, SO51 0HR United Kingdom  
Company Number 08350831 | VAT Number GB 156 8355 80